

# **What is the Coronal Heating Problem?**

James A. Klimchuk  
Naval Research Lab

# Professor Waves, Bernie Roberts



# Professor Reconnection, Eric Priest



# How do we make progress on the coronal heating problem?

## What challenges do we face?

- Disparate spatial scales (physically linked)
- Variability and dynamics
- Complex micro physics
- Observational ambiguities

# Coronal Heating Flow Chart

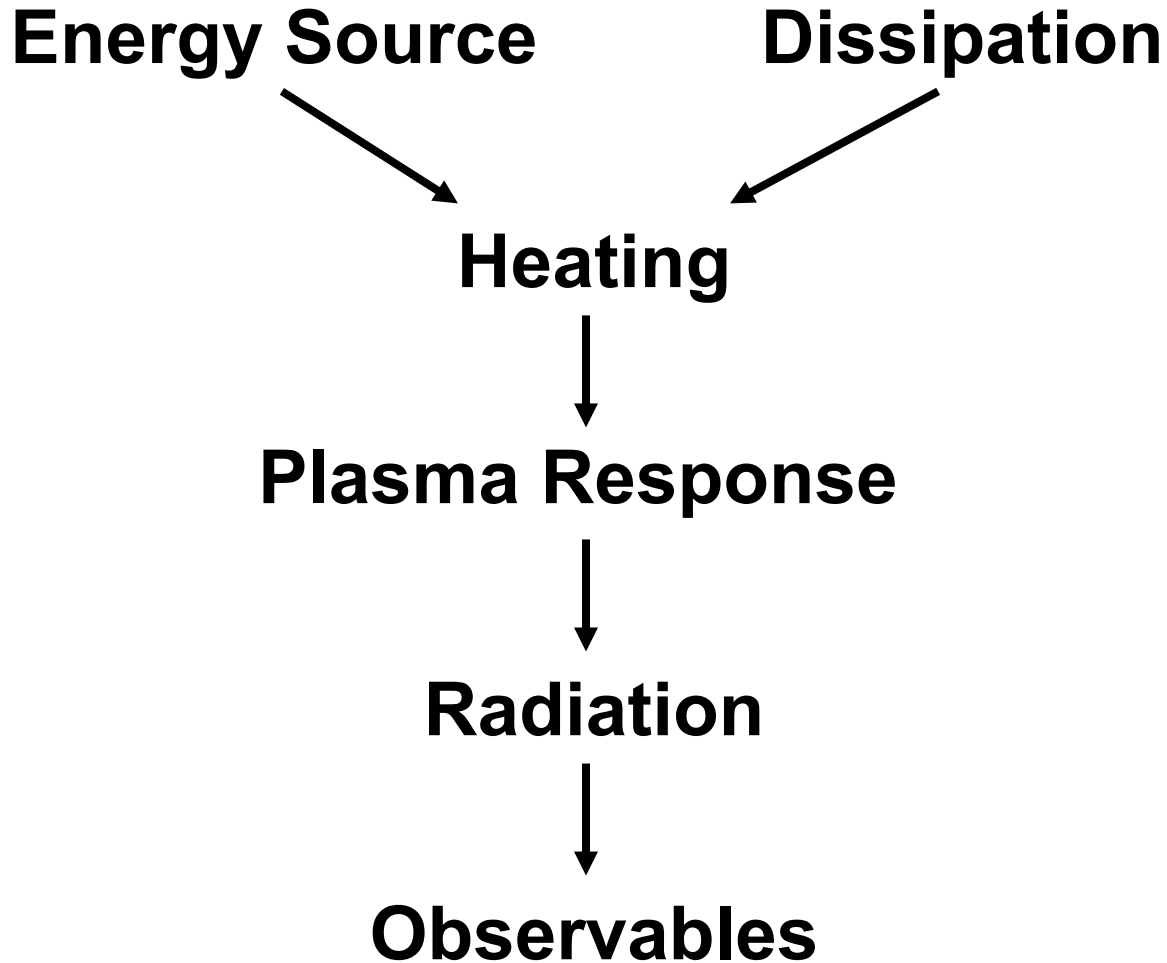

# Coronal Heating Flow Chart

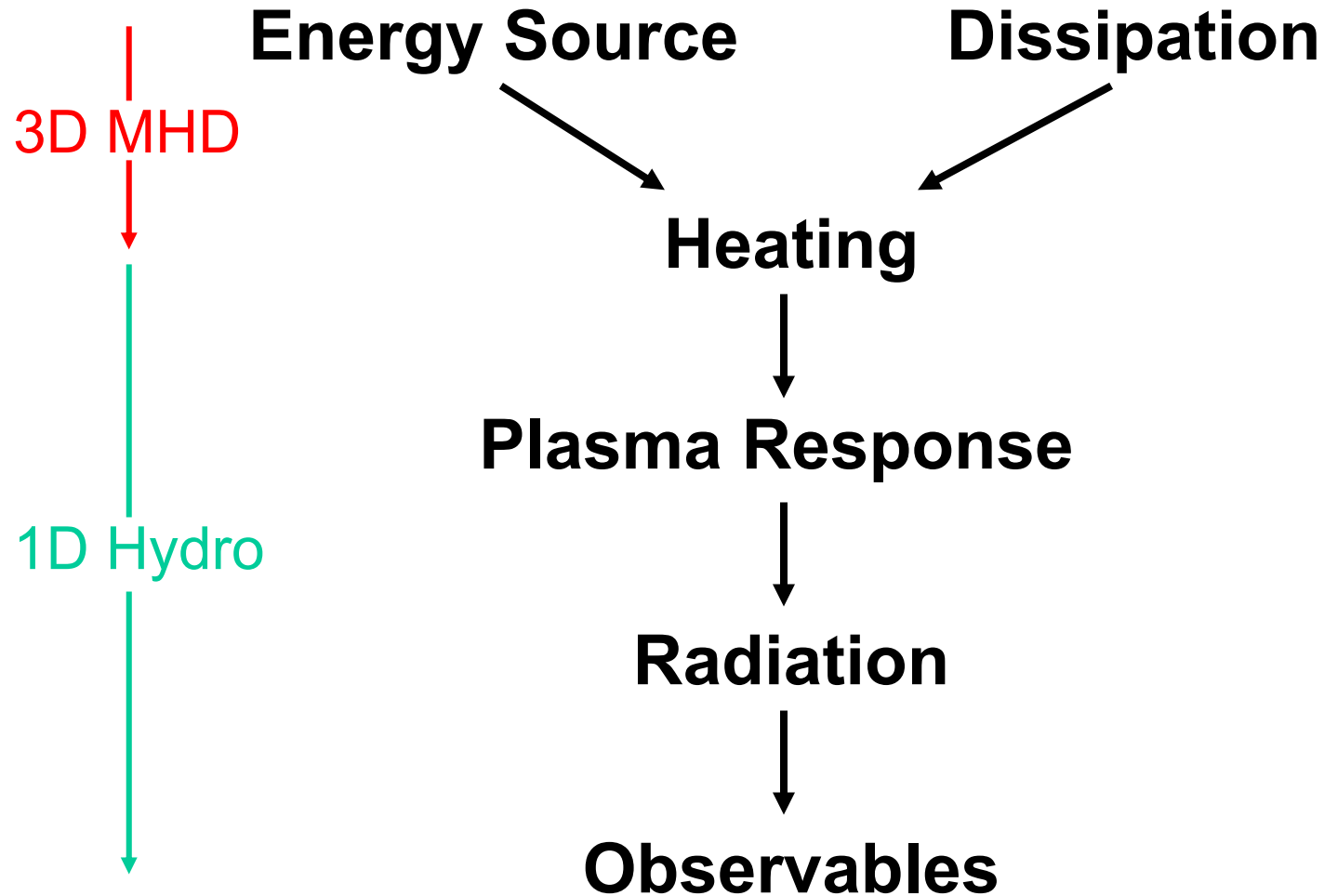

# Coronal Heating Flow Chart

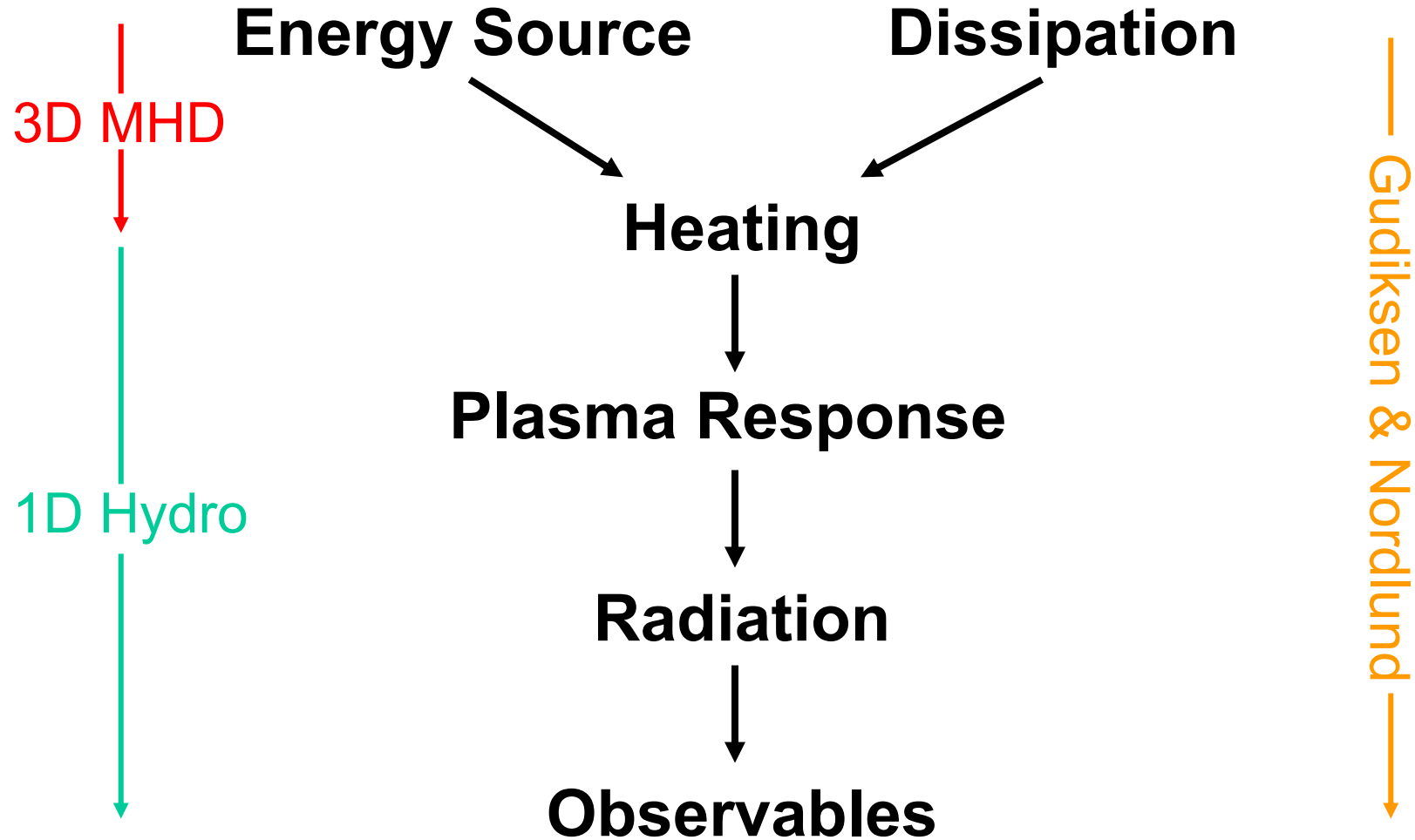

# Coronal Heating Flow Chart

**Energy Source**

**Dissipation**

**Heating**

**Plasma Response**

**Radiation**

**Observables**

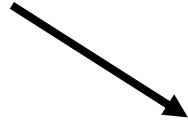

# Energy Source

- Waves (AC)
  - Is there a sufficient energy flux?
  - At the right frequencies?
- Magnetic stresses (DC)
  - Footpoint driving more than adequate
  - Level of stress depends on the dissipation!

# Coronal Heating Flow Chart

**Energy Source**

**Dissipation**

**Heating**

**Plasma Response**

**Radiation**

**Observables**

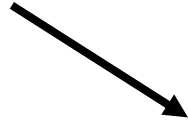

# Dissipation

- Very small spatial scales required
- Anomalous transport coefficients
  - Shear viscosity or resistivity enhanced  $> \times 10^5$   
(Nakariakov et al. '99, Ofman & Aschwanden '02)
  - Resistivity *locally* enhanced by  $> \times 10^3$   
(e.g., Parker '73, Biskamp '93)
  - Thermal conduction = classical  
(e.g., Klimchuk, Tanner, De Moortel '04)
- Collisionless reconnection  
(e.g., Birn, Drake, et al. 2001)

# Dissipation (cont.)

- Must “switch on” at right level of stress

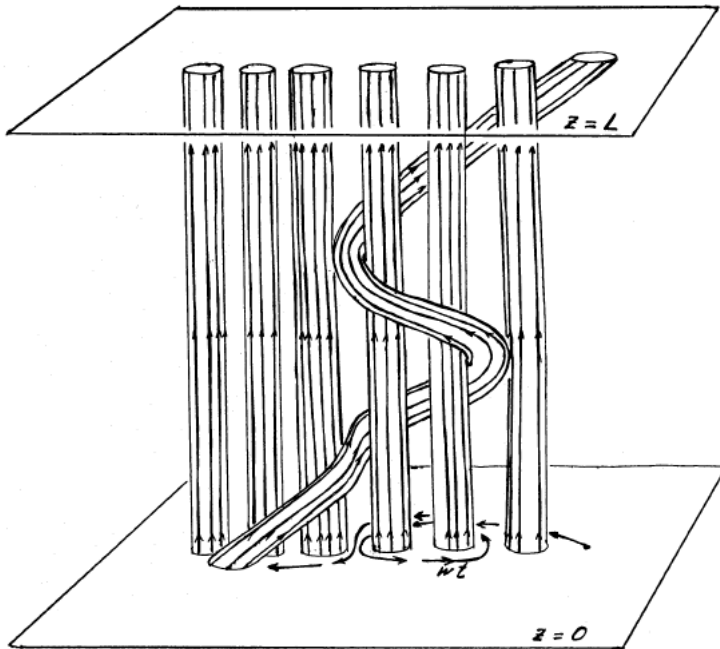

Poynting flux:

$$F = \frac{1}{4\pi} B_v B_h v_h$$

$$F \approx 10^7 \text{ erg cm}^{-2} \text{ s}^{-1}$$

$$B_v \approx 100 \text{ G}$$

$$v_h \approx 0.2 \text{ km s}^{-1}$$

$$\theta = \arctan \left( \frac{B_h}{B_v} \right) \approx 30^\circ$$

Parker (1983), Priest et al. (2002)

# Coronal Heating Flow Chart

**Energy Source**

**Dissipation**

**Heating**

**Plasma Response**

**Radiation**

**Observables**

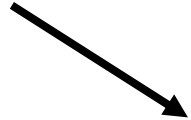

# Plasma Response

- Coupling of the corona to the transition region and chromosphere is *critical*
  - Static equilibrium models  
(energy and force balance)
  - Dynamic models  
(chromospheric evaporation and condensation)

# Response to Nanoflare

Evolution of temperature, density, pressure, velocity (averaged over loop)

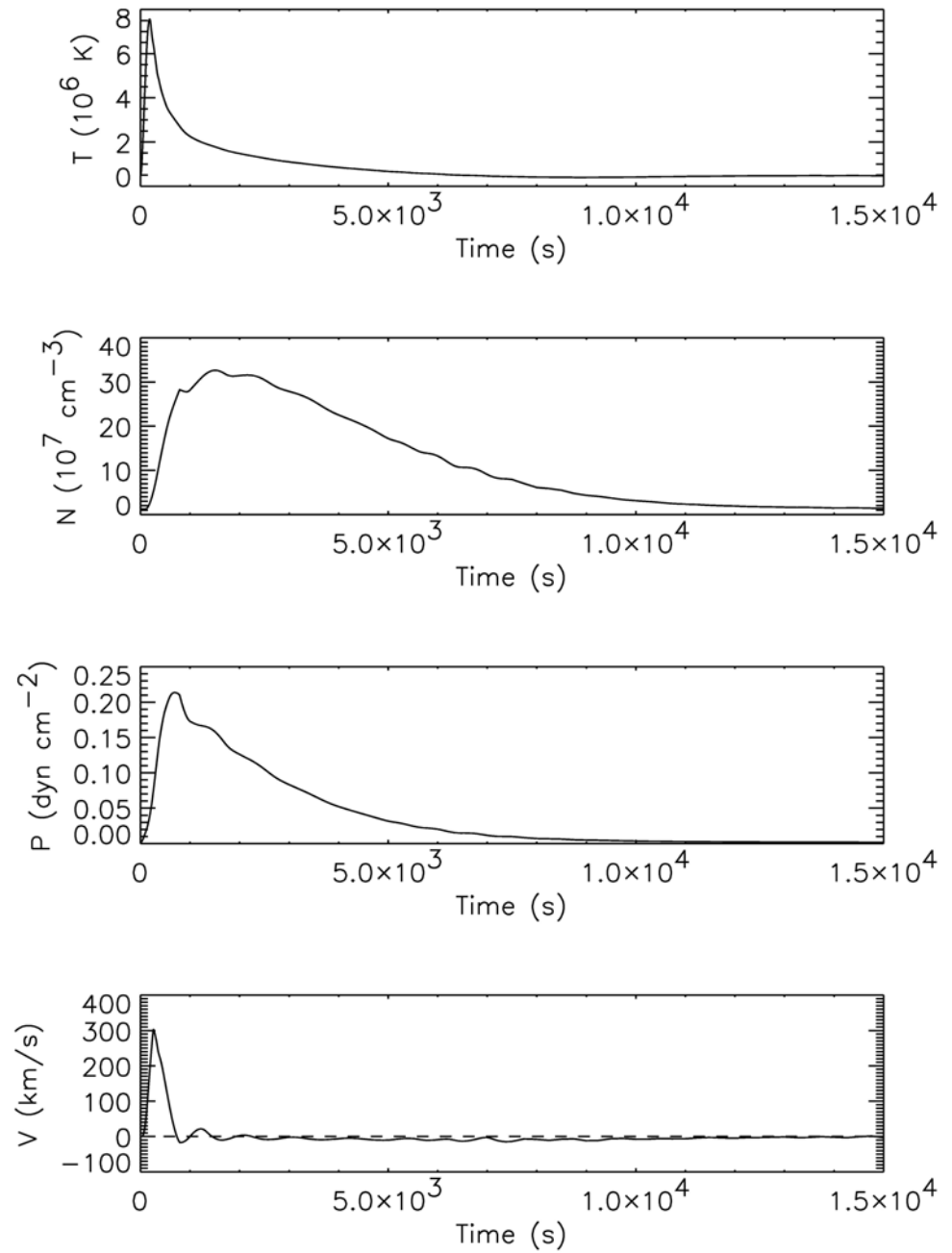

# Response to Nanoflare

Instantaneous temp.,  
density, velocity  
profiles (t = 220 s)

Heat flux:

Saturated (solid)

Classical (dashed)

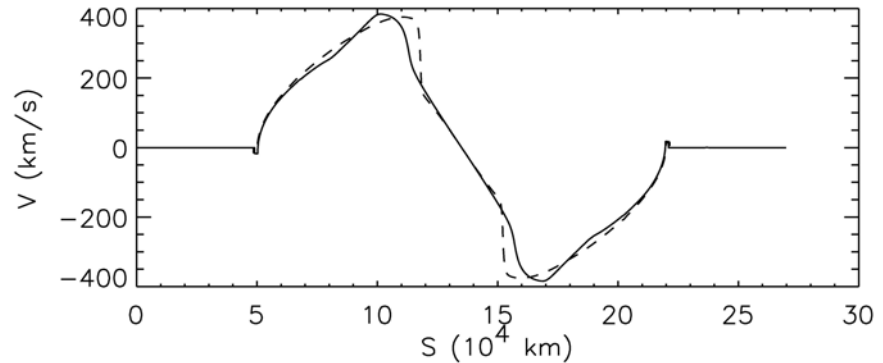
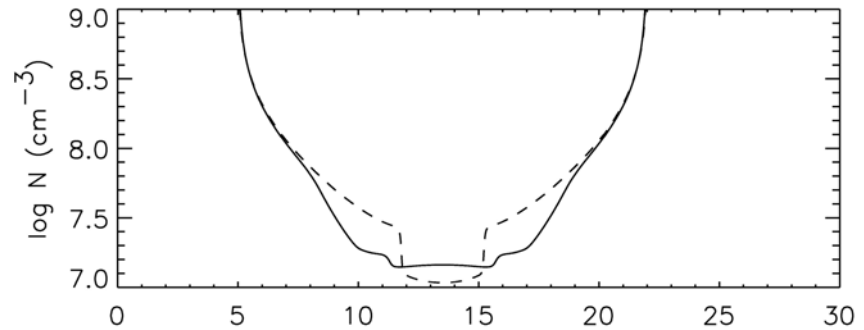
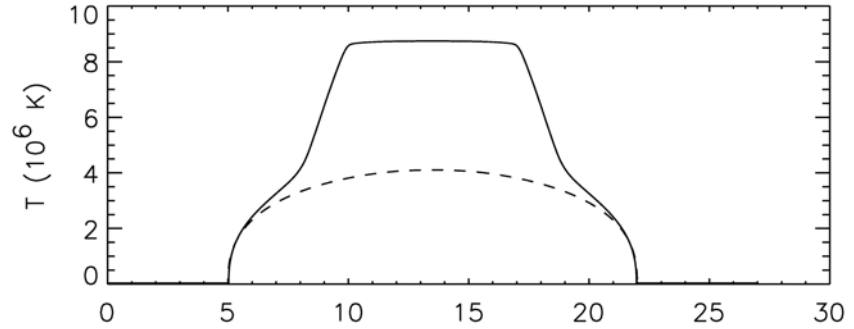

## Plasma Response (cont.)

- Involves small spatial scales
  - transition regions, shocks
- Critical for making meaningful observational predictions
- Can fundamentally affect the heating itself
  - e.g., resonant wave absorption

# Resonant Absorption of Alfvén Waves

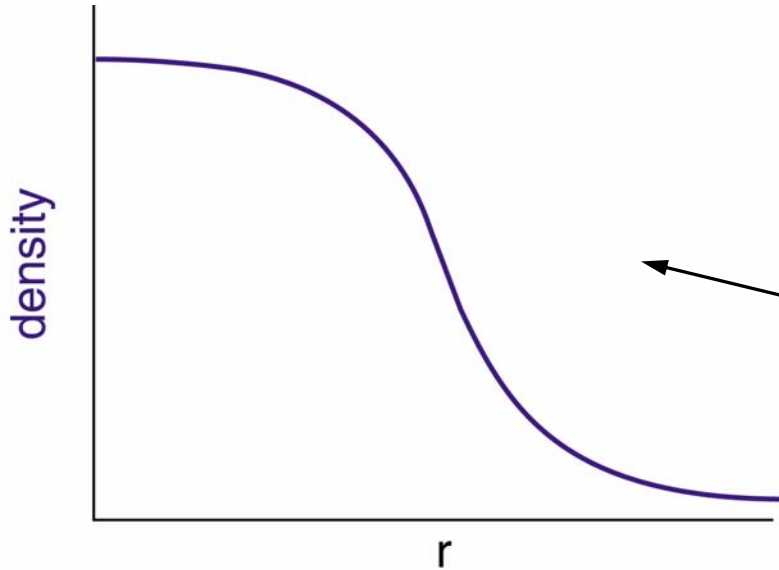

Assumed density profile  
(density vs. radial position)

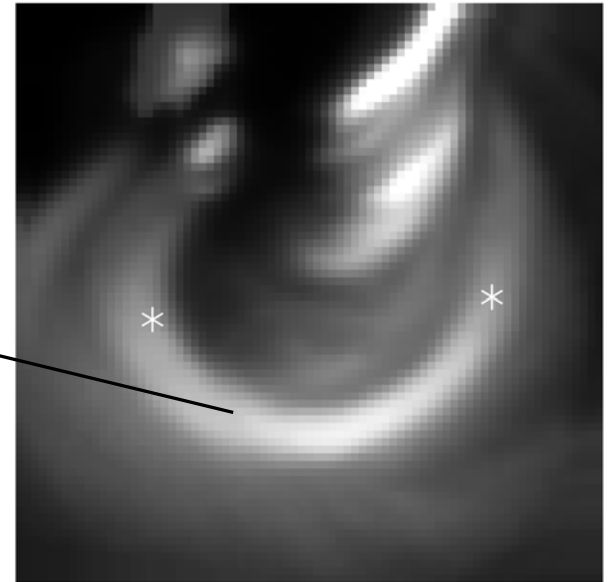

X-ray loop observed  
by Yohkoh

# Resonant Absorption of Alfvén Waves

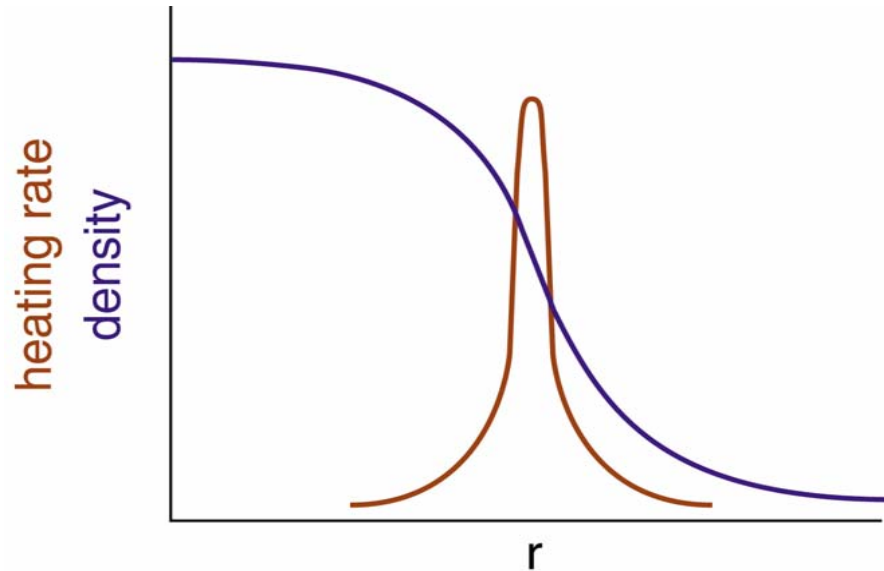

Resulting heating profile

# Resonant Absorption of Alfvén Waves

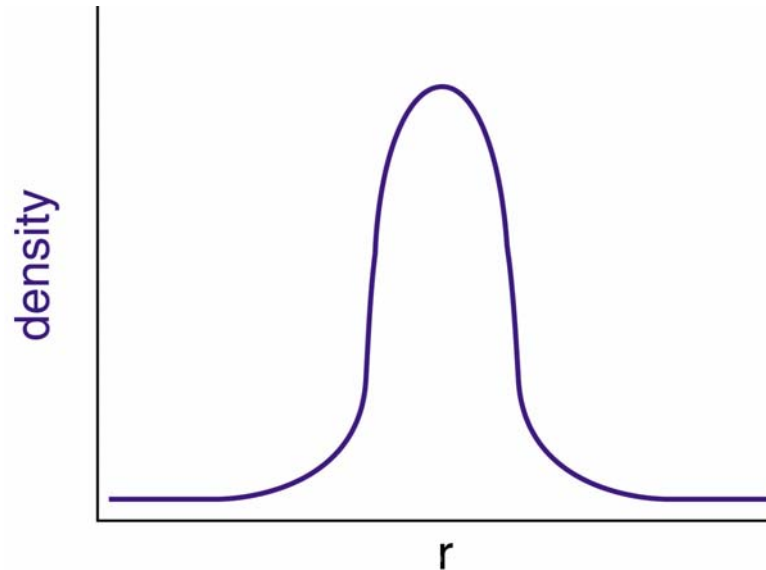

New density profile in response to heating

# Resonant Absorption of Alfvén Waves

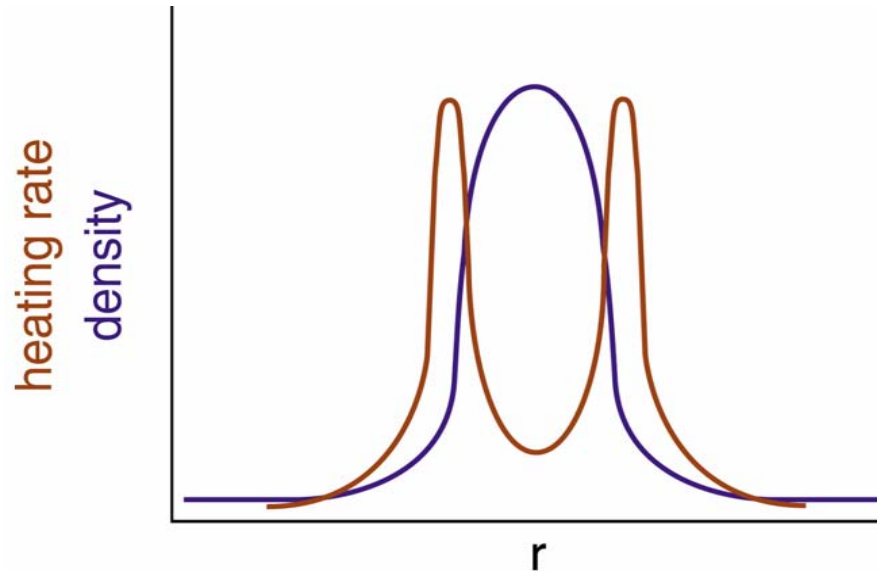

Resulting new heating profile .....

# Heating Rate vs. Position

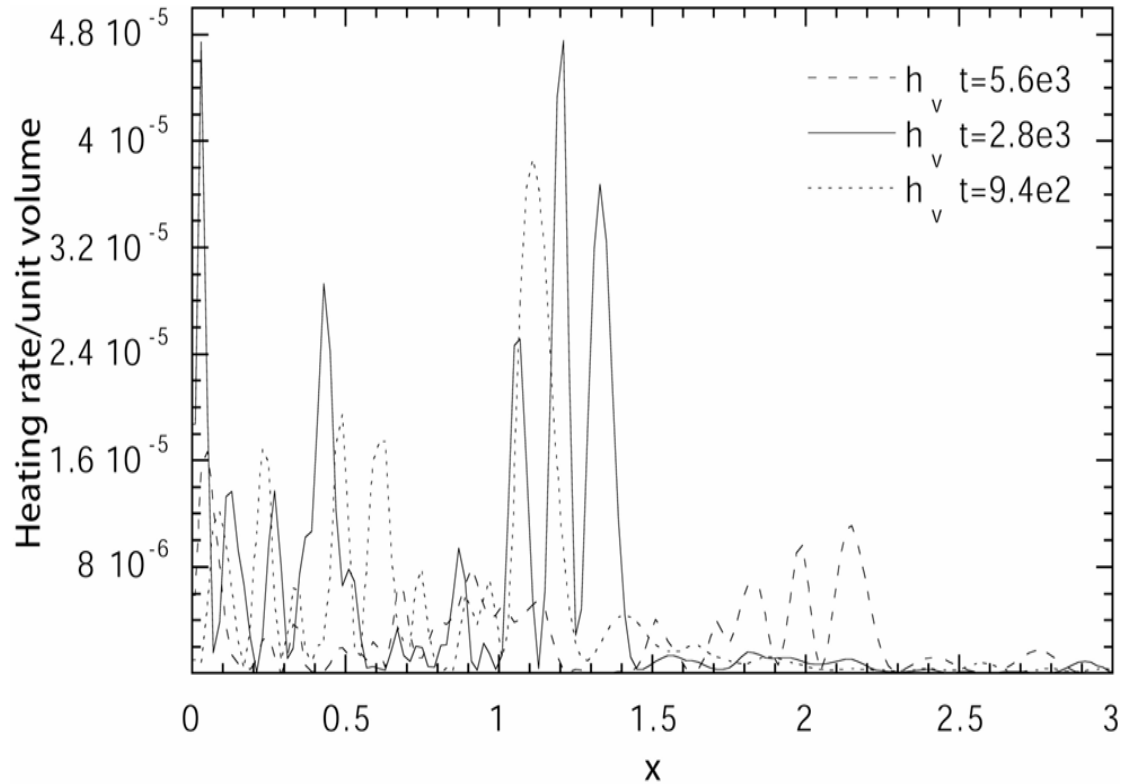

Ofman, Klimchuk, & Davila (1998)

# Plasma Response (cont.)

- Must consider individual field lines  
(elemental coronal strands)

Heating is impulsive in *steady* reconnection !!!

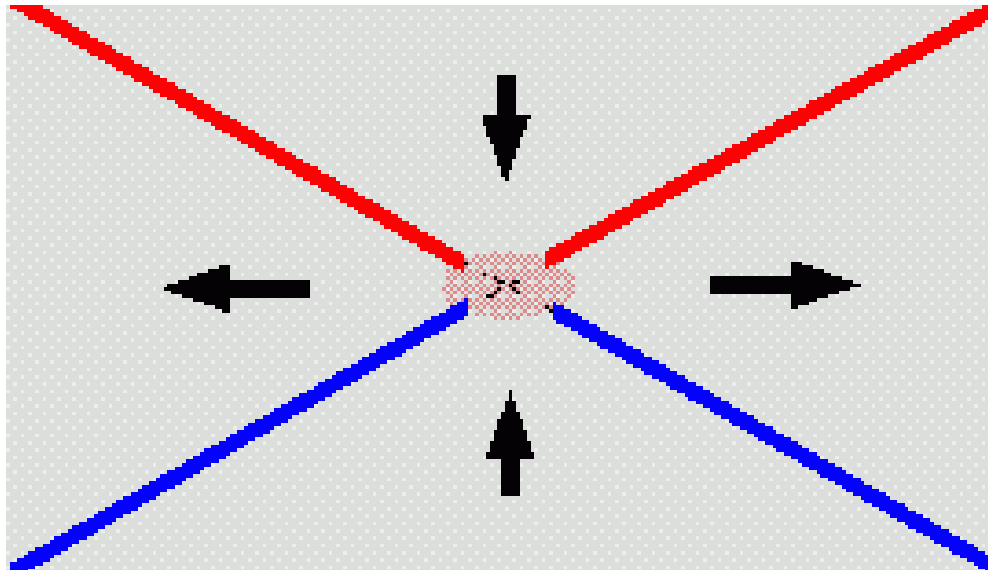

unknown credit

# Coronal Heating Flow Chart

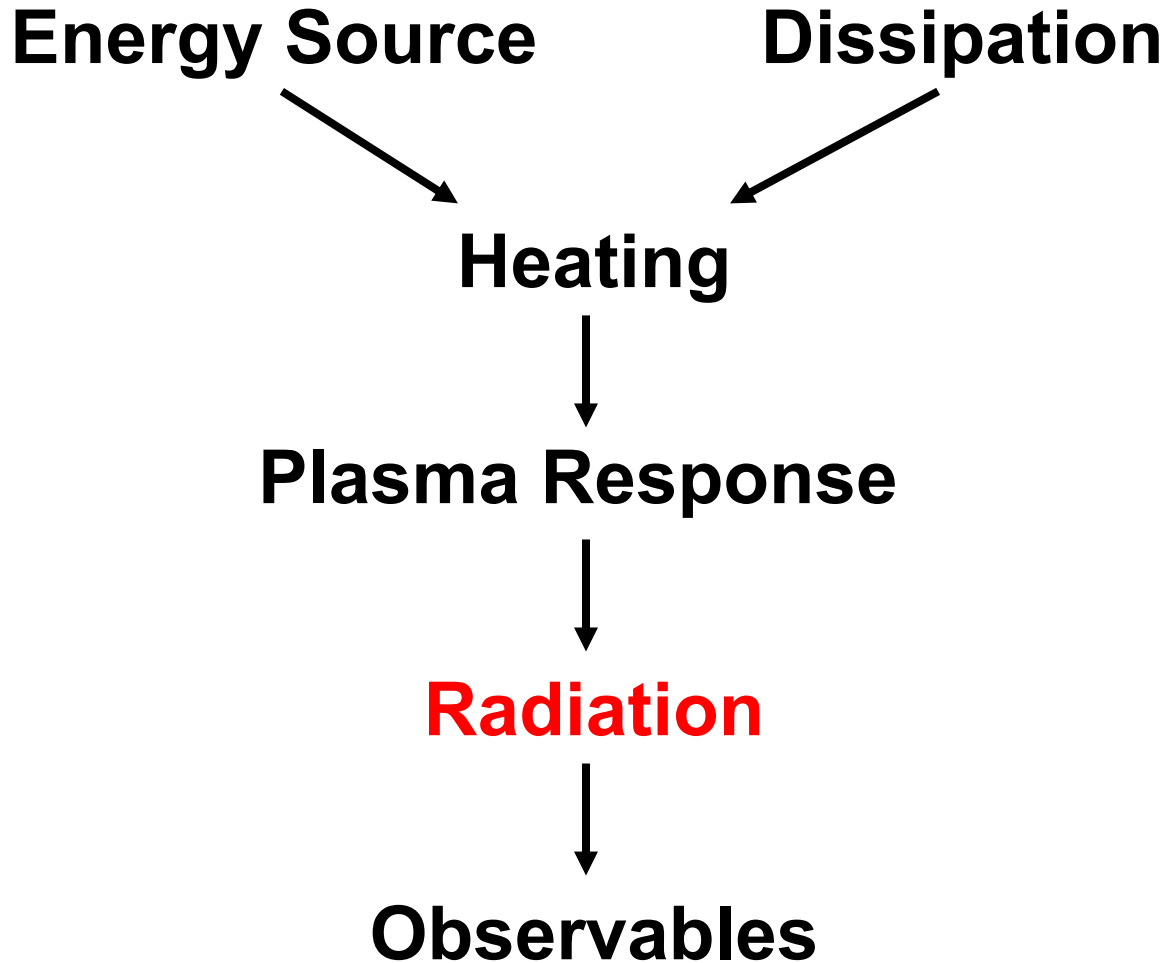

# Radiation

- Ionization non-equilibrium
  - Rapid time variability
  - Flow through steep temperature gradient
- Abundances
  - FIP effect
- Affect observational diagnostics more than physical evolution

# Coronal Heating Flow Chart

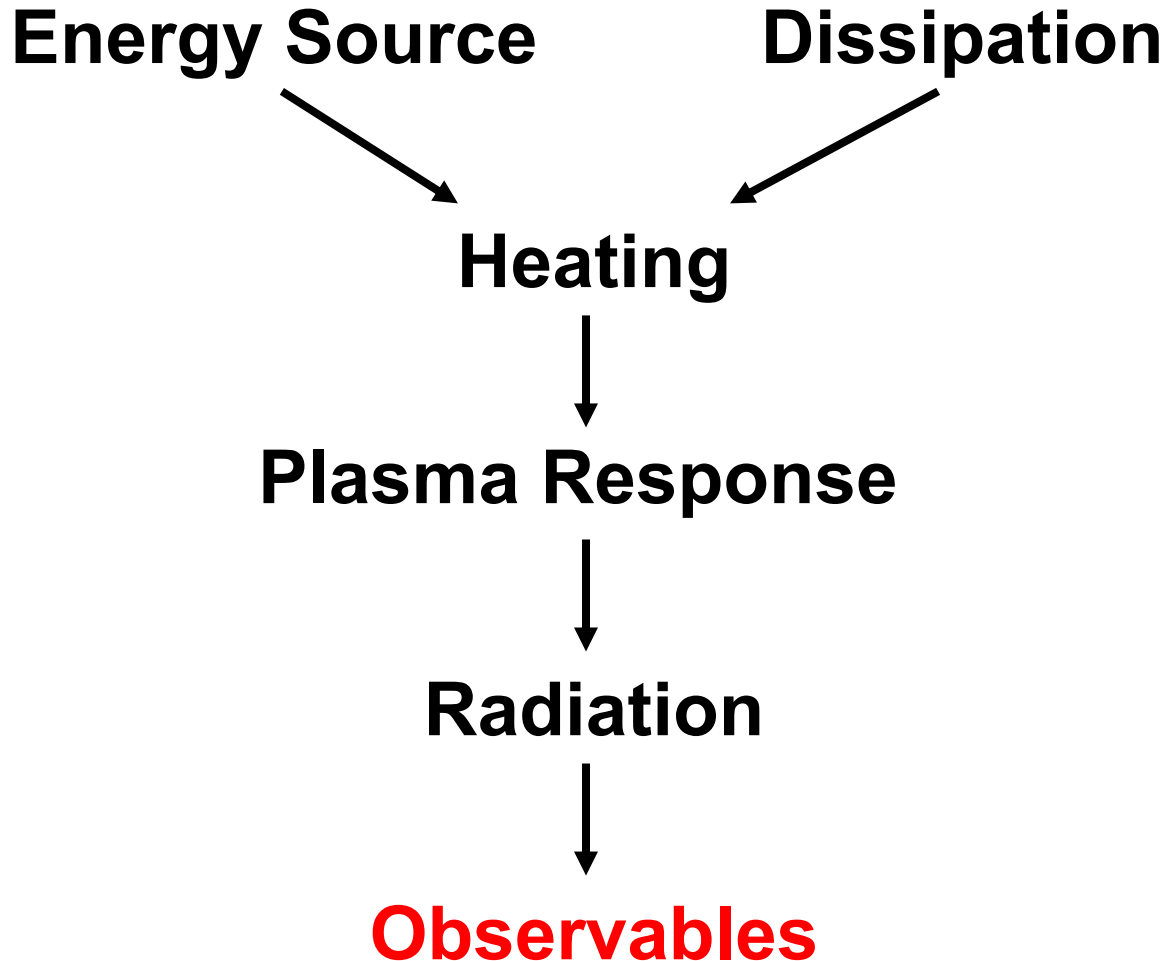

# Observables

- Sources of ambiguity & confusion
  - Integration over space, especially along l-o-s
  - Integration over time
  - Integration over wavelength (temperature)
  - Density-squared weighting
  - Ionization non-equilibrium
- Inversion can be dangerous  
(infer  $n$ ,  $T$ ,  $DEM$ , etc. from data)
- Forward modeling safest  
(predict intensities and line profiles)

## Observables (cont.)

- Need high-speed imaging spectrometer
  - Broad temperature coverage ( $10^5 - 10^7$  K)
  - High temperature fidelity
  - High spatial resolution ( $< 1$  arcsec)
  - Modest field-of-view (1 arcmin)
  - Modest cadence (1 min)

# Recommendations

- Need to address the complete problem  
(first principles idea → detailed prediction of obs.)
- Must treat:
  - Small spatial scales
    - Current sheets, resonant layers, turbulence, etc.
    - Transition regions, shocks
  - Variability and dynamics
    - Chromospheric evaporation and condensation

# Recommendations (cont.)

- Must treat:
  - Micro physics
    - Anomalous transport coefficients
    - Collisionless reconnection
    - Saturated and non-local heat flux
    - Ionization non-equilibrium
    - Particle acceleration
  - Observational limitations
    - Forward modeling
    - New imaging spectrometer

# “Klimchuk’s Choice”

## (for the moment!)

- Parker’s picture of tangled field is essentially correct
- Tangling occurs on a sub-resolution scale (i.e., internal to observed coronal loops)
- Heating is due to secondary instability at the current sheet interfaces between elemental magnetic flux tubes

# “Klimchuk’s Choice”

## (for the moment!)

- X-ray and EUV observations suggest that a single corona loop is comprised of many unresolved strands heated impulsively and quasi-randomly by nanoflares (as first proposed by Cargill, 1994)
  - e.g., over and under densities relative to static equil.  
(Aschwanden et al.; Winebarger et al.; Porter & K)

# Density Relative to Static Equilibrium

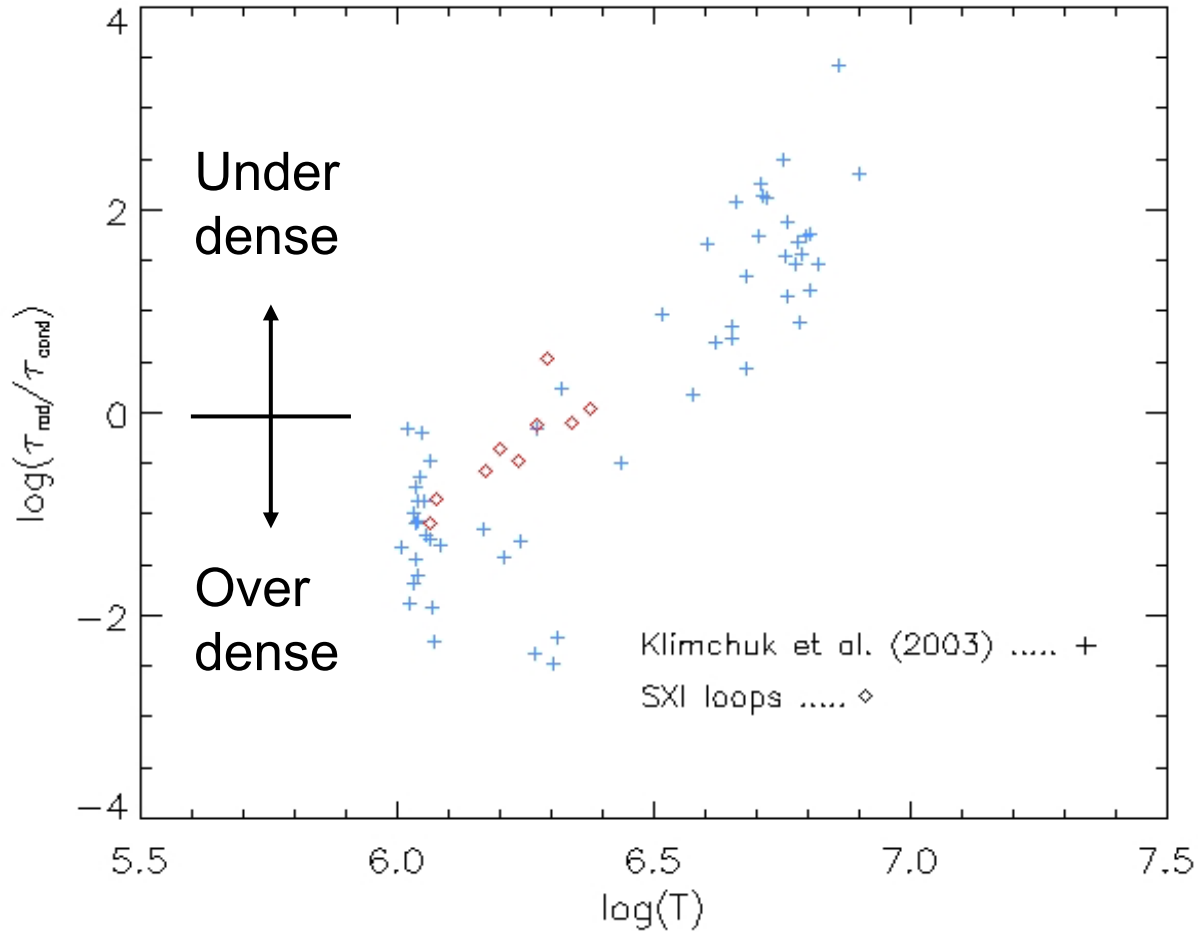

Lopez-Fuentes, Mandrini, & Klimchuk (2004)

## “Klimchuk’s Choice” (cont.)

- A single coronal loop contains 100’s of elemental kG flux tubes
- Footpoints are randomly displaced about the surface
- There *must* be reconnection in the corona; otherwise:
  - Adjacent footpoints would become widely separated
  - Coronal tangling would increase monotonically
  - The observed coherence of loops would not exist
- Reconnection with the low-altitude “magnetic carpet” does *not* help

## “Klimchuk’s Choice” (cont.)

- Secondary instability
  - Impulsive energy release
  - “Switches on” at the Parker angle
- Predicts the characteristic diameter of observed loops

# Secondary Instability

Impulsive heating switches on at the “Parker angle”

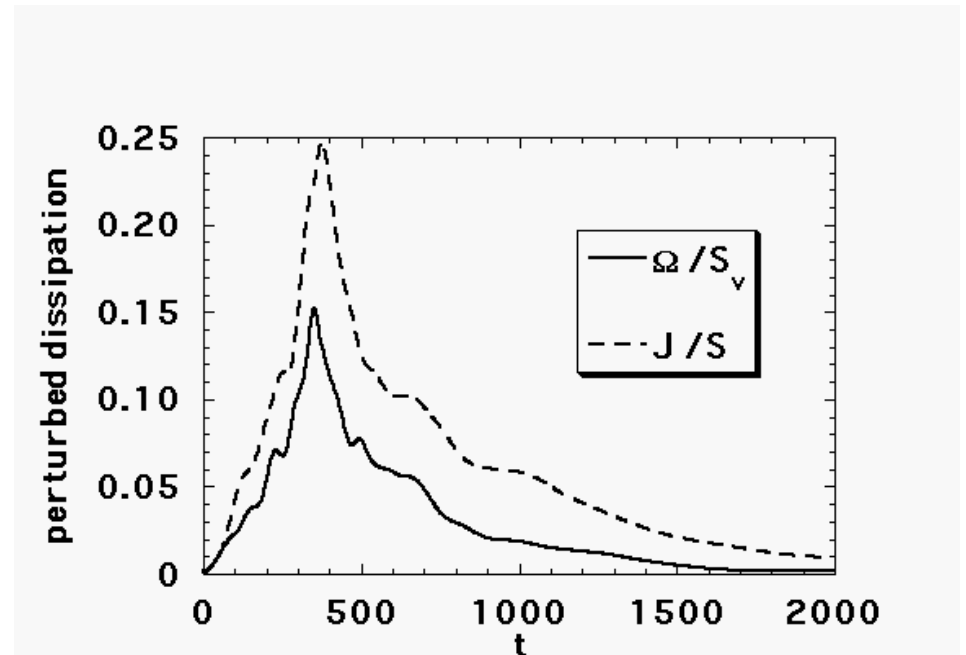
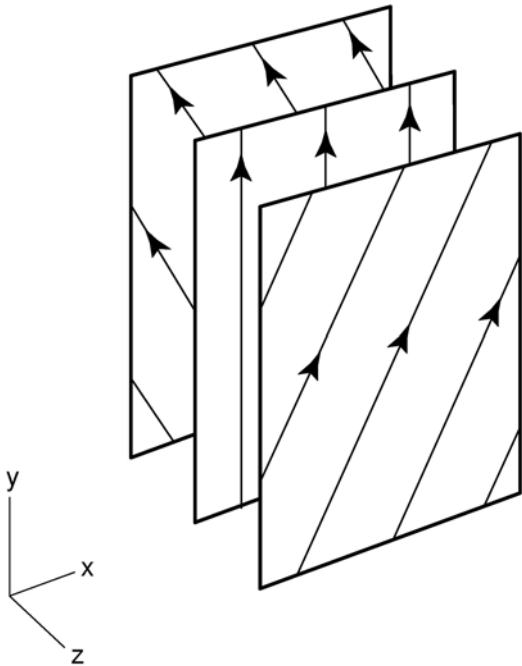

Dahlburg, Klimchuk, & Antiochos (2003)

## “Klimchuk’s Choice” (cont.)

- Secondary instability
  - Impulsive energy release
  - “Switches on” at the Parker angle
- Predicts the characteristic diameter of observed loops

# **Extra Slides**

# Loop Light Curve

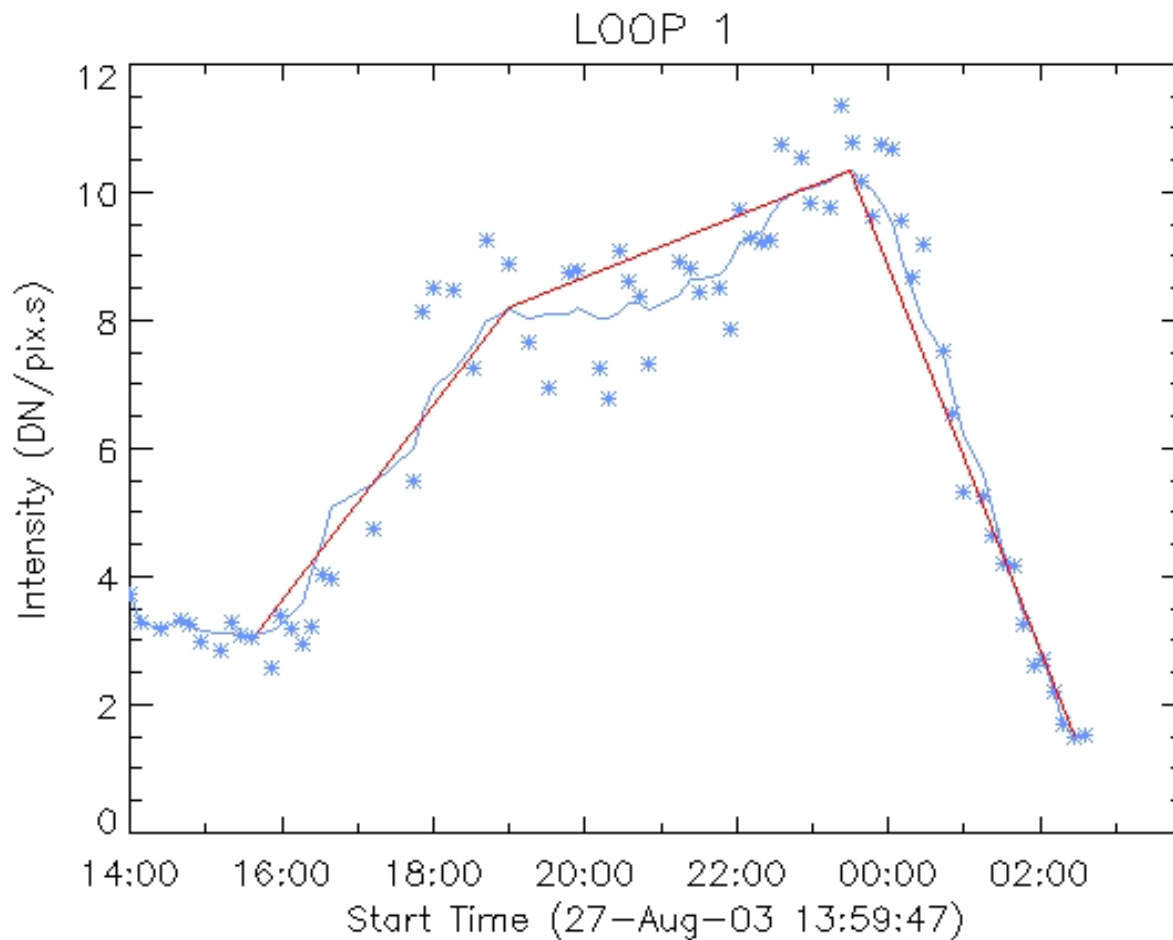

Lopez-Fuentes, Mandrini, & Klimchuk (2004)

# Footpoint Symmetry

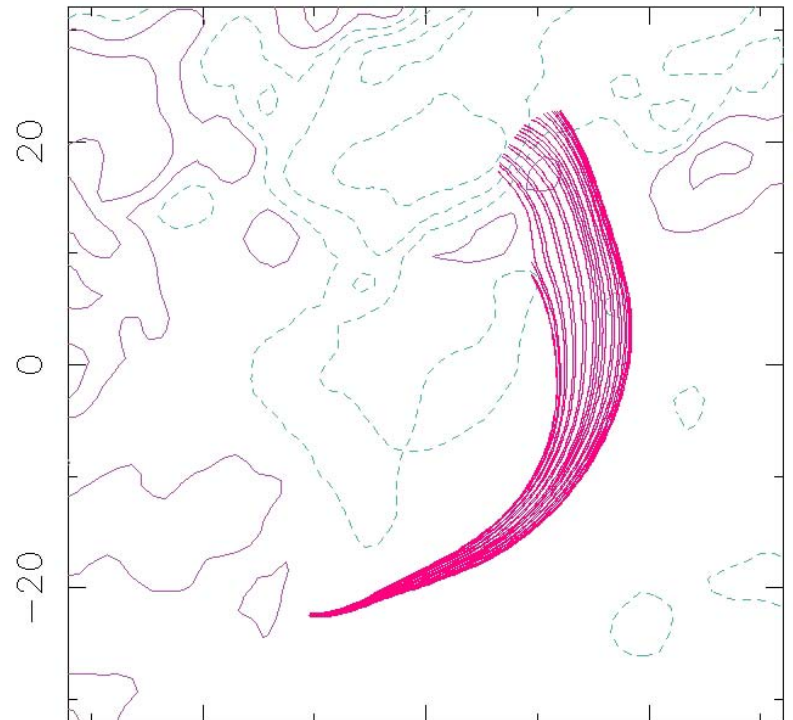
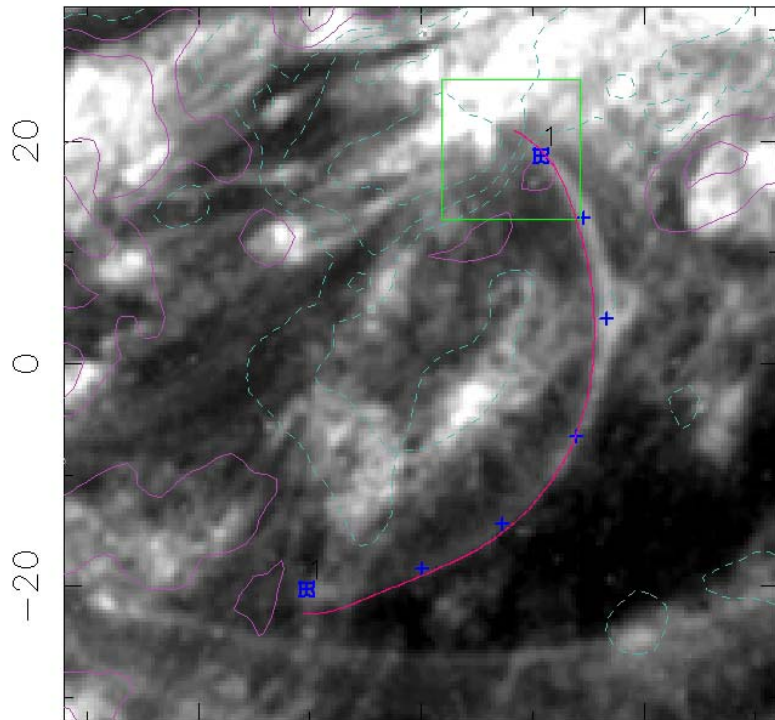

Lopez-Fuentes & Klimchuk (2004)

# Cooling Time Ratio vs. Temperature

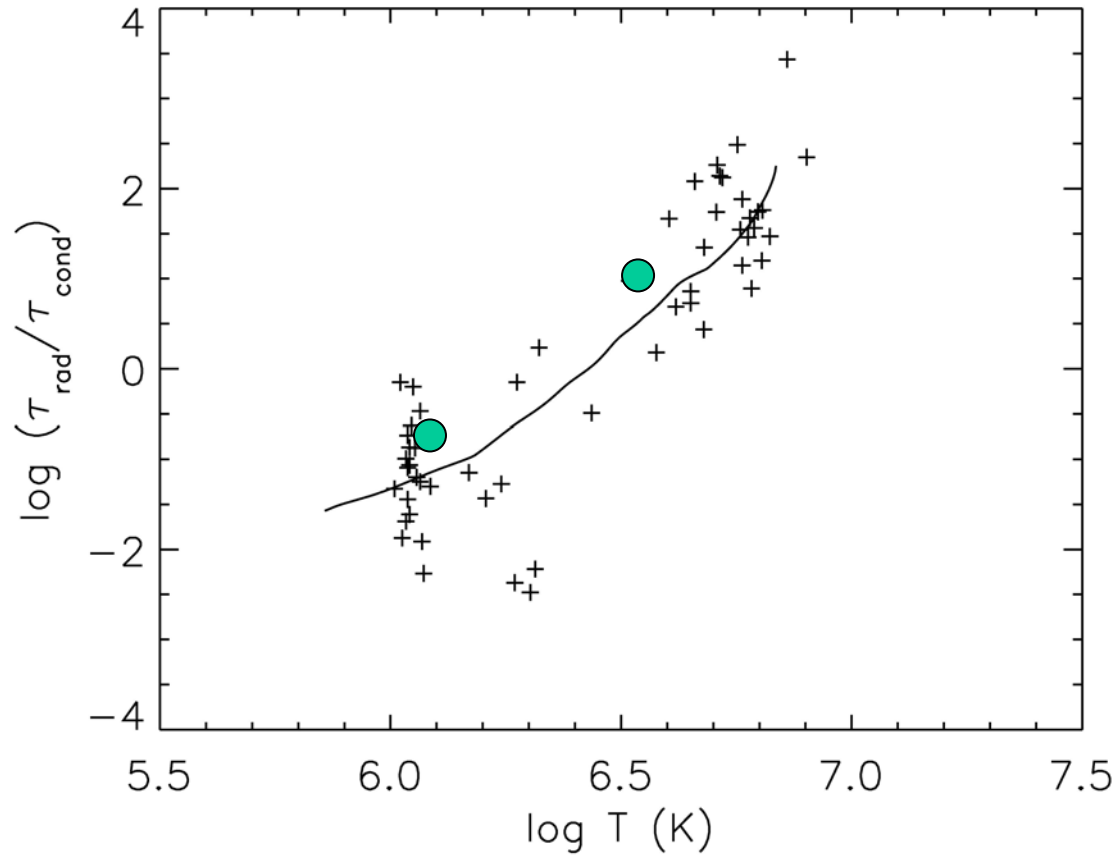

# Nanoflare DEM(T)

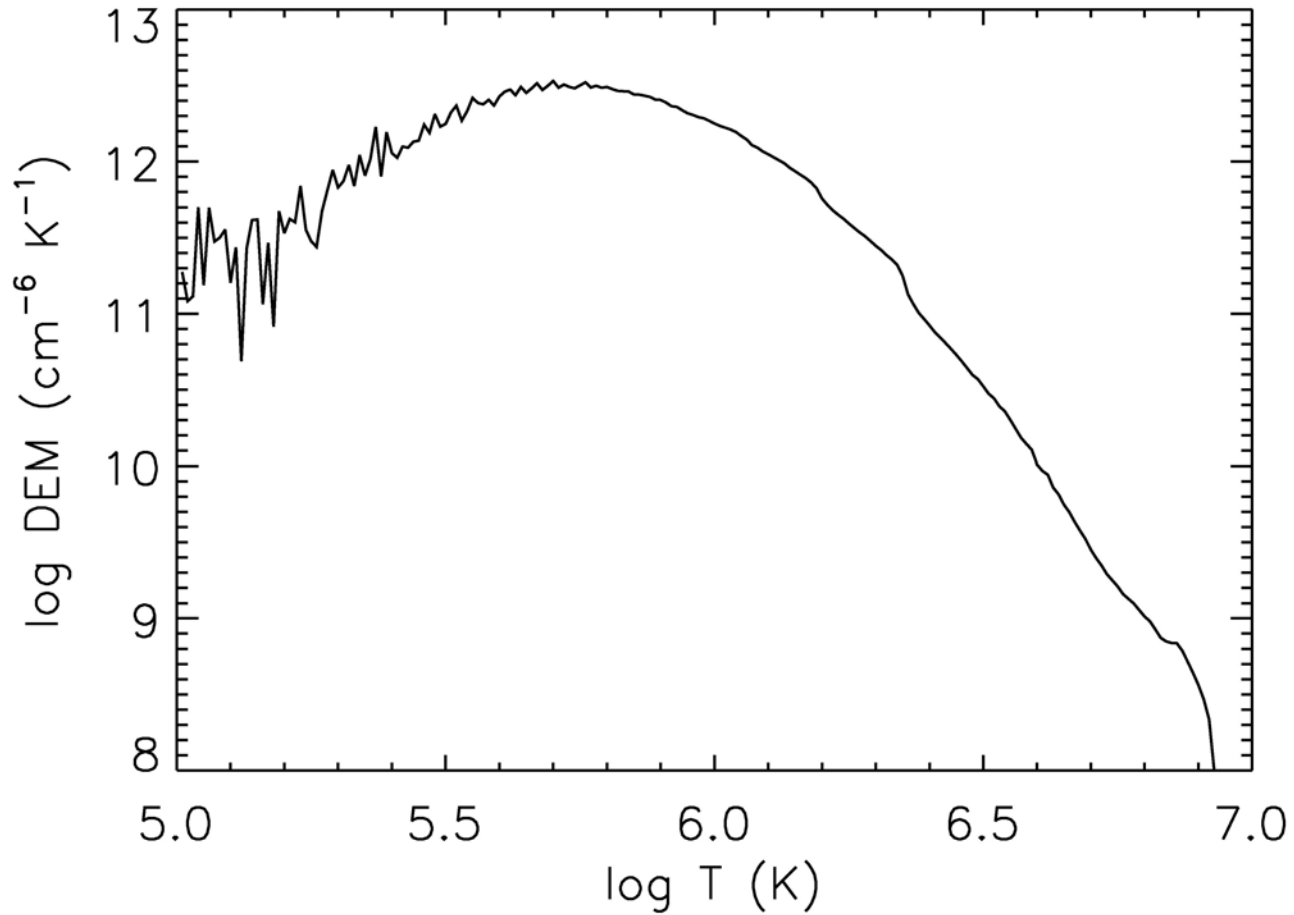

# Generating Large Gradients

DC models:

- Complex field and simple boundary flow
- Simple field and complex boundary flow
- Coronal turbulence
- Instabilities

AC models:

- Resonance layers
- Phase mixing
- Counter streaming

# Complex Field & Simple Flow

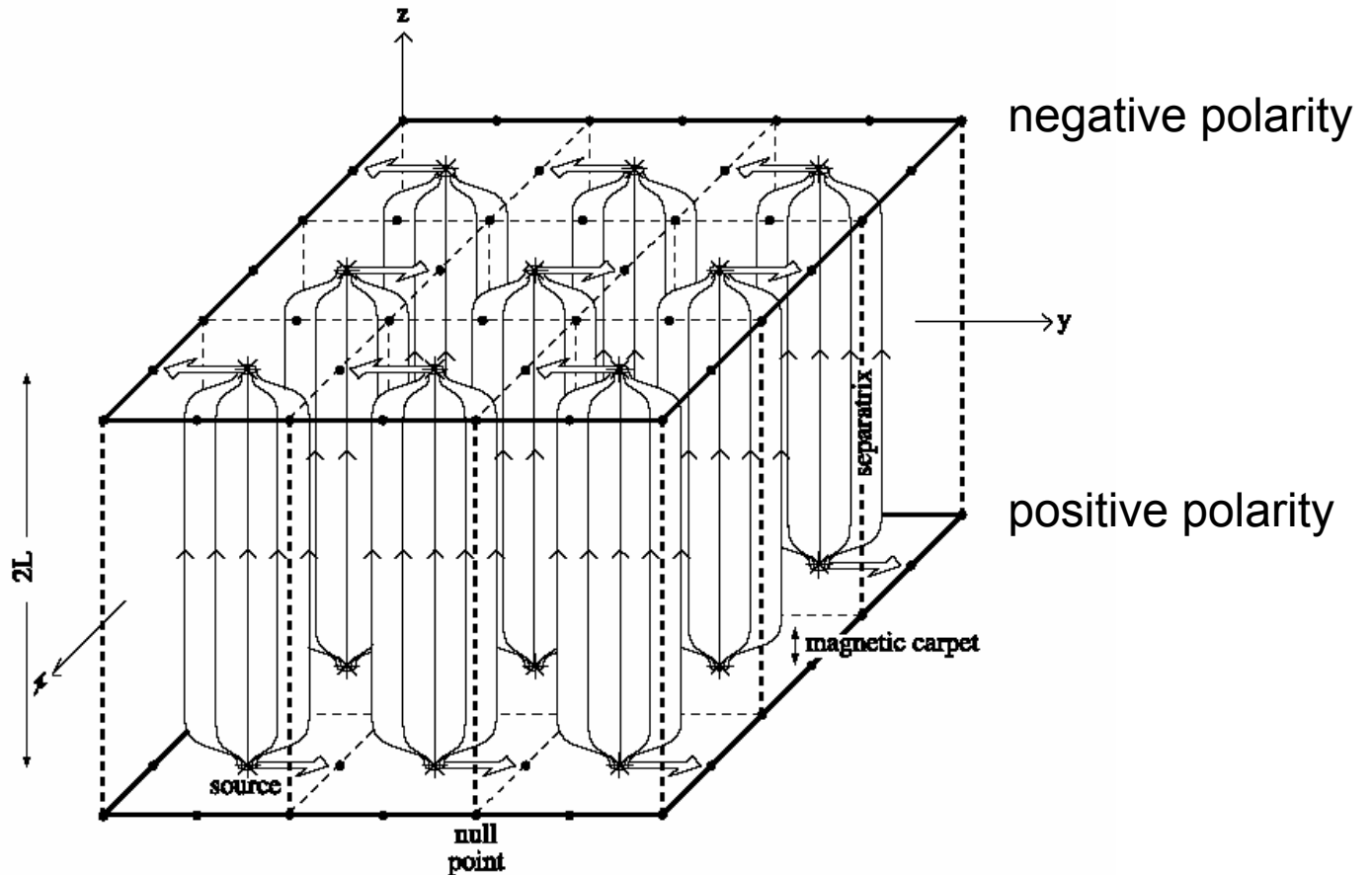

Priest, Heyvaerts, & Title (2002)

# Complex Field & Simple Flow

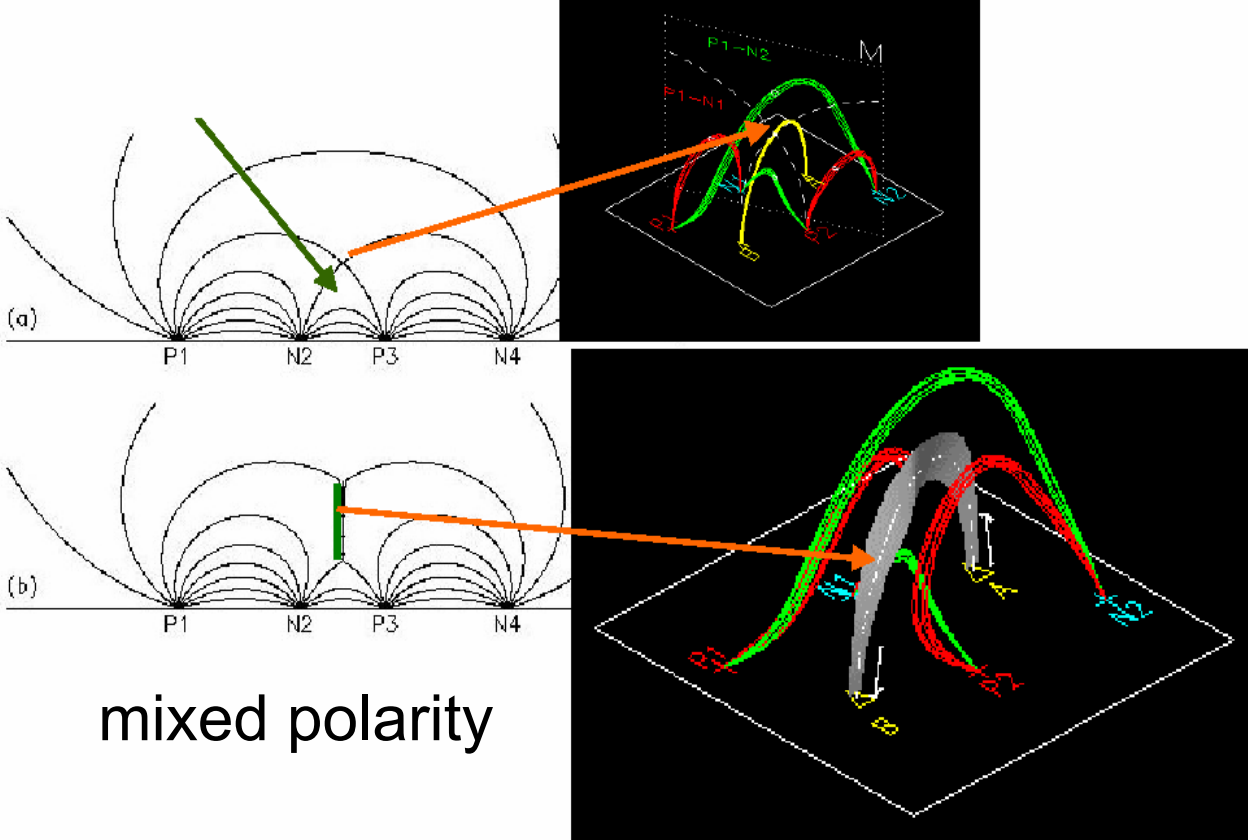

Longcope (2003)

# Complex Field & Simple Flow

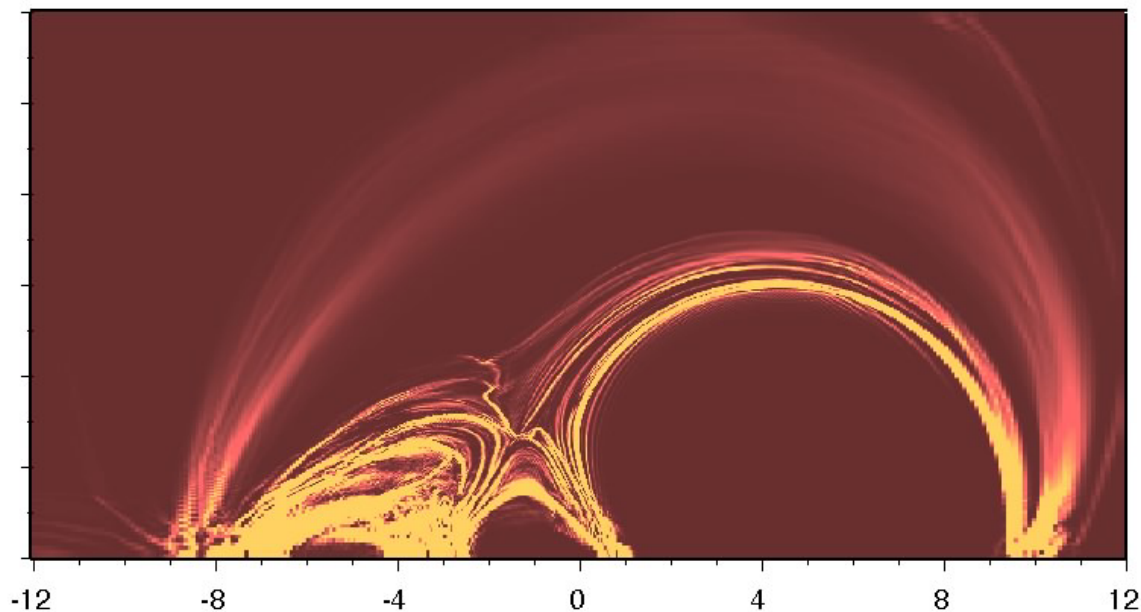

Reconnection  
Driven  
Current  
Filamentation

distance ( $10^3$  km)

0   $\geq 10^3$  (arbitrary units)

Electric Current Magnitude ( $J_x^2 + J_y^2$ ) at 1400 s

Karpen, Antiochos, & DeVore (1996)

# Simple Field and Complex Flow

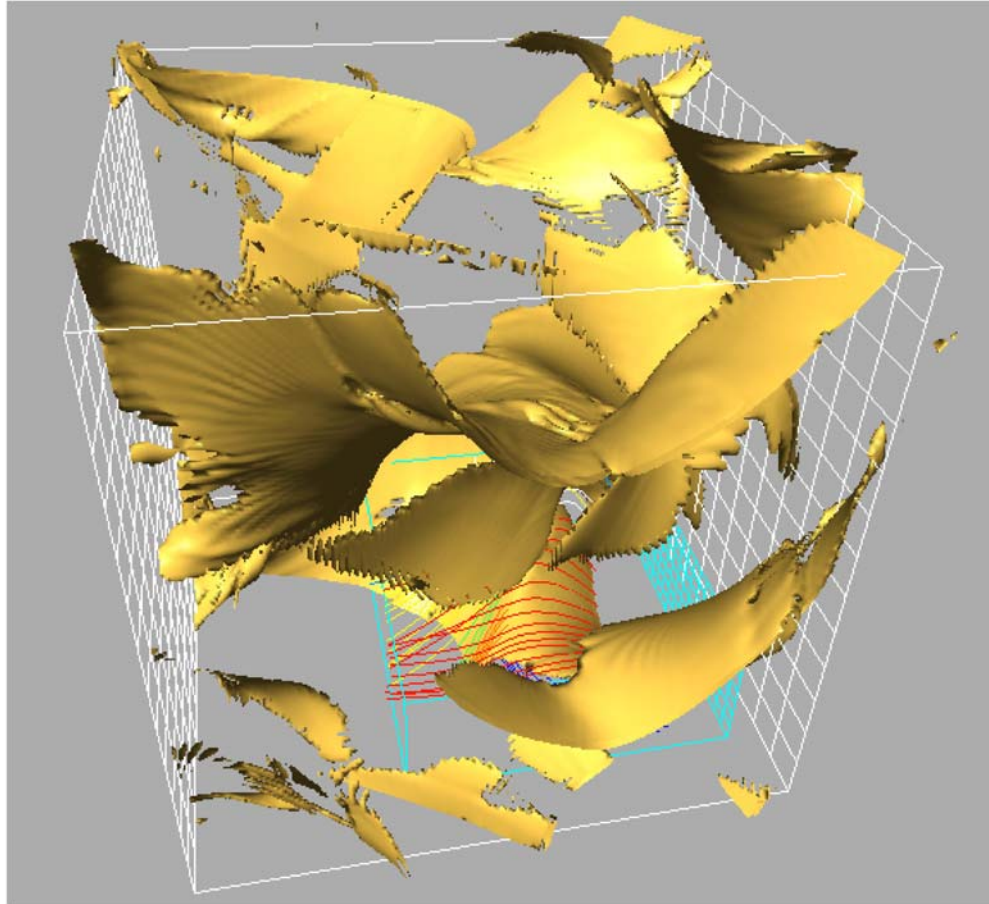

Electric  
current  
isosurfaces

Galsgaard & Nordlund (1996)

# Coronal Turbulence

Magnetic field over image of j

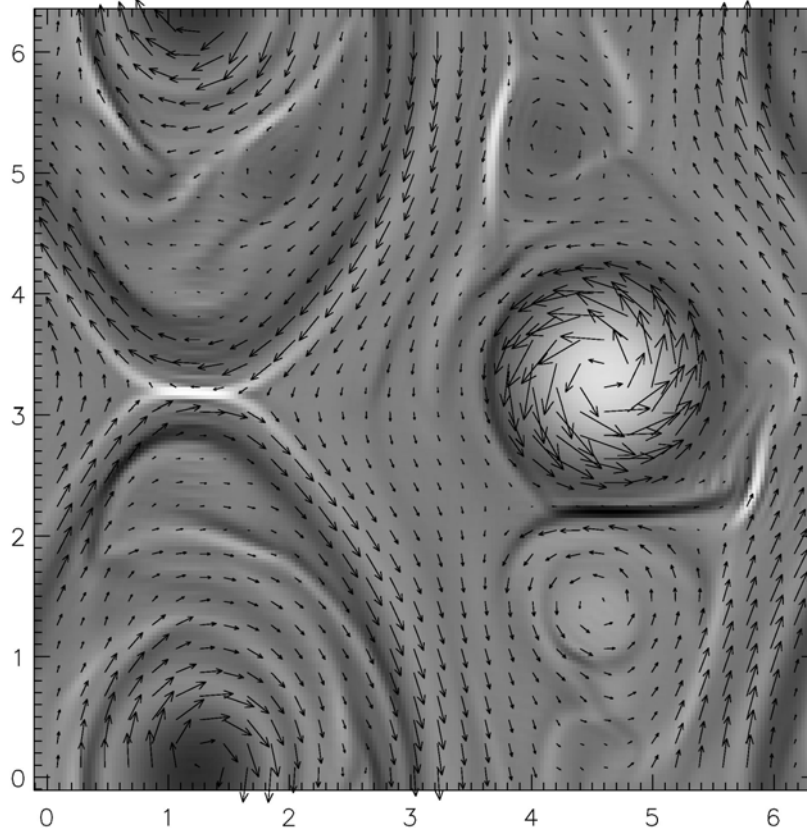

Dmitruk, Gomez,  
& DeLuca (1998)

# Kink Instability

Electric Current

Lionello, Velli,  
Einaudi, & Mikic  
(1998)

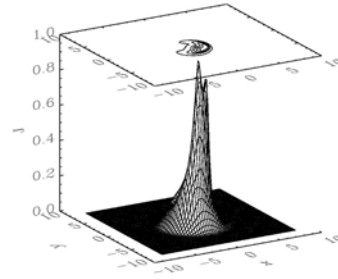
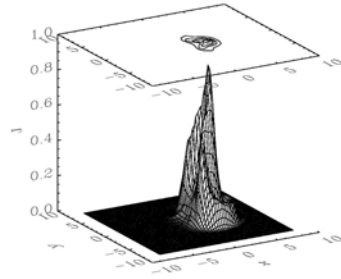

twist profile 1

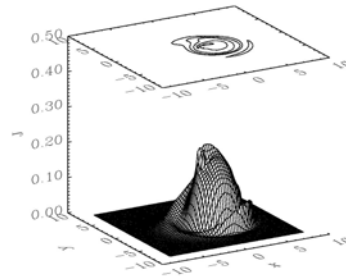
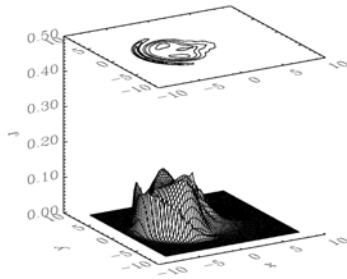

twist profile 2

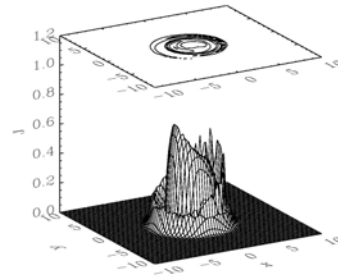
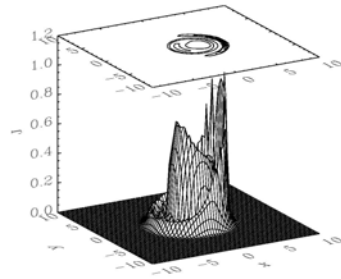

twist profile 3

apex

leg